

■ 1920 X 1200

■ 162 fps

Go-X Series 

❖ **GOX-2402-USB**
2.3-megapixel CMOS global shutter

USB[™]
VISION



- *Go-X Series delivers exceptional combination of price and performance*
- *2.3-megapixel, 1/2.3" CMOS imager (global shutter)*
- *Up to 162 fps at full resolution (1920 x 1200)*
- *3.45 μm square pixels*
- *8/10/12-bit* output in choice of monochrome or raw Bayer color models*
- *ROI settings for added flexibility*
- *Horizontal/vertical image flip function, plus blemish correction and shading compensation*
- *Includes Sequencer function and Automatic Level Control (ALC) for dynamic lighting conditions*
- *Compact size with excellent shock and vibration resistance*
- *Accepts power over USB3 Vision interface or via separate 6-pin connector*
- *C-mount lens mount*

* Not all processing functions supported with 12-bit output

Specifications for GOX-2402-USB

Go-X Series

Specifications	GOX-2402-USB
Sensor	1/2.3" CMOS global shutter (IMX392)
Active pixels	1920 (h) x 1200 (v)
Frame rate, full frame	162 frames/sec. @ 8-bit mono/Bayer
Active area	6.62 mm (h) x 4.14 mm (v) - 7.81 mm diagonal
Pixel size	3.45 μm x 3.45 μm
System clock	74.25 MHz (for pulse generator)
Read-out modes	Full ROI (single) 1920 (h) x 1200 (v) up to 162 fps H: 96 to 1904 pixels in 16 pixel steps V: 8 to 1198 lines in 2 line steps Binning 1x2, 2x1, 2x2
EMVA 1288 Parameters	10-bit output format
Absolute sensitivity	Mono: TBD p Color: TBD p (λ = 525 nm)
Maximum SNR	Mono: TBD dB Color: TBD dB
Traditional SNR*	>60 dB mono, >60 dB color (0 dB gain, 10-bit)
Video signal output	Monochrome: 8/10/12-bits† Color: 8/10/12-bit Bayer†
Gain	Manual/auto 0 dB to +24 dB
White balance	Off, presets, or one-push/continuous AWB
Gamma/LUT	0.45 to 1.0 (9 steps) or 257-point programmable LUT
Synchronization	Internal
Video modes	Normal/Single ROI, Sequencer (Trigger & Command)
Trigger input	Opto In, Pulse Generators (4), Software, NAND Out (2), User Output (4)
Exposure modes	Timed/EPS, RCT, Trigger Width, Auto
Electronic shutter	Timed: 14.73 μs to 8 sec. in 1 μs steps Auto: 100 μs to 6.1 ms at full resolution
Auto Level Control (ALC)	Shutter range from 100 μs to 6.1 ms, gain range from 0 dB to +24 dB. Tracking speeds and max. values adjustable.
Shading correction	Flat shading, color shading (color model)
Pre-processing functions	H & V flip (mirroring), blemish compensation, H & V decimation
Operating temp. (ambient)	-5°C to +45°C (20 to 80% non-condensing)
Storage temp. (ambient)	-25°C to +60°C (20 to 80% non condensing)
Vibration	10G (20 Hz to 200 Hz, XYZ directions)
Shock	80G
Regulations	CE(EN 55032:2015(CISPR32:2015), EN 55035:2017(CISPR35:2016)), FCC Part 15 Class B, RoHS/WEEE, KC
Power	6-pin USB 3.0 +10V to +25V DC. 4.2 W typical @ +12 V +5V DC. 4.35 W typical @ +5 V
Lens mount	C-mount
Dimensions (H x W x L)	29 mm x 29 mm x 51.5 mm
Weight	62 g

Ordering Information

GOX-2402M-USB	Monochrome camera with USB3 Vision interface
GOX-2402C-USB	Color camera with USB3 Vision interface

*Traditional SNR is based on random noise in a single frame, where EMVA SNR measurements consider more comprehensive noise sources and variance over time.

†12-bit output available in video processing bypass mode. See manual for details.

Europe, Middle East & Africa
Phone +45 4457 8888
Fax +45 4491 8880

Asia Pacific
Phone +81 45 440 0154
Fax +81 45 440 0166

Americas
Phone (Toll-Free) 1 800 445 5444
Phone +1 408 383 0300

Visit our website on www.jai.com

Dimensions

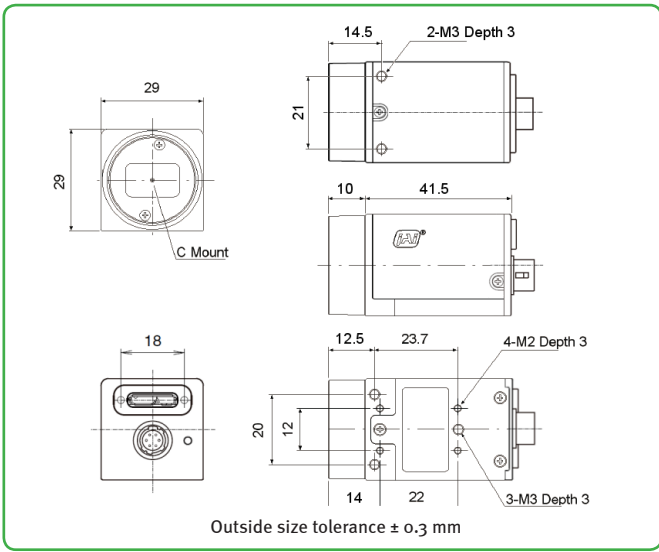

Connector pin-out

DC In / Trigger

HIROSE HR10A-7R-6PB(73)

Pin

- 1 DC in +10V to +25V
- 2 Opto In 1
- 3 Opto Out 1
- 4 Opto Out 2
- 5 Opto Common
- 6 Ground

USB 3.0 Interface

Micro B type - ZX3600-B-10P or equiv.

No.	I/O	Name	Note
1	I	VBUS IN	Power (VBUS)
2	I/O	DM	USB2.0 Differential pair (-)
3	I/O	DP	USB2.0 Differential pair (+)
4		OTG ID	USB OTG ID for identifying lines
5		GND	GND
6	O	FX3 SSTXM	USB3.0 Signal Transmission line (-)
7	O	FX3 SSTXP	USB3.0 Signal Transmission line (+)
8		GND	GND
9	I	FX3 SSRXP	USB3.0 Signal Receiving line (-)
10	I	FX3 SSRXM	USB3.0 Signal Receiving line (+)

Spectral Response

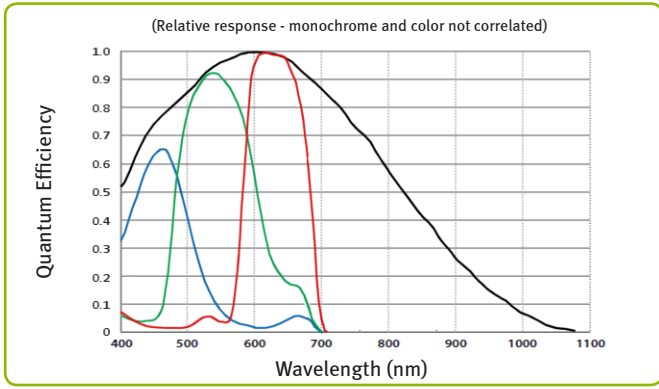

Company and product names mentioned in this datasheet are trademarks or registered trademarks of their respective owners. JAI A-S cannot be held responsible for any technical or typographical errors and reserves the right to make changes to products and documentation without prior notice.



See the possibilities